

G&P MACHINERY BROCHURE

BROCHURE

Manufacturer of Grinding and Polishing Machinery-Designer and Builder of Special Machinery for Specific Grinding Applications

- Pressure Grinders
- Polishing Lathes
- Stroke Sanders
- Swing Grinders
- Cylindrical Polishers
- Grinding Lathes
- Custom Designs

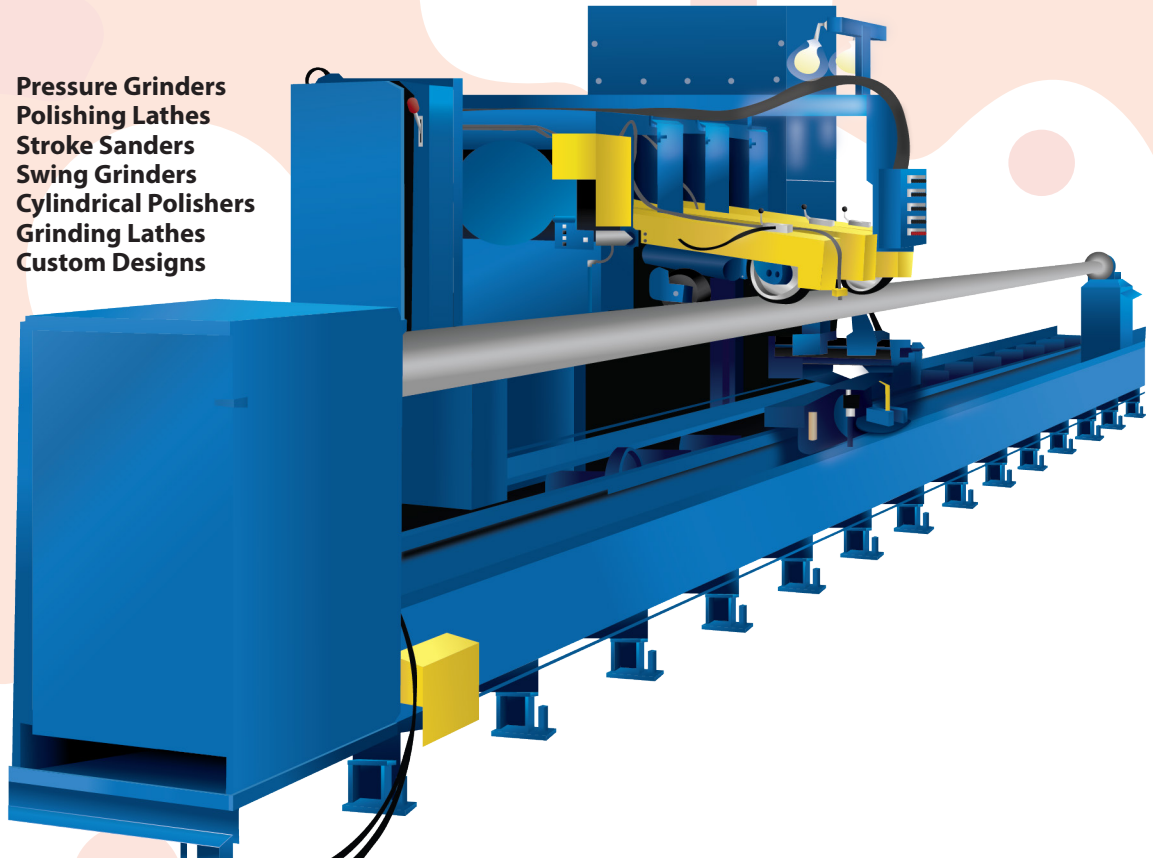

Light Pole Polisher

Polishes light poles up to 40 FT long with (3) 15 HP grinders Using 6" x 132" Belts.



GRINDING & POLISHING MACHINERY CORPORATION

2801 TOBEY DRIVE / INDIANAPOLIS, IN 46219

PHONE (317) 898-0750 • FAX (317) 899-1627

G&P MACHINERY BROCHURE

BROCHURE

Wolfhead

Brush backed sanding head is perfect for sanding and polishing flat, contour and irregular shapes.

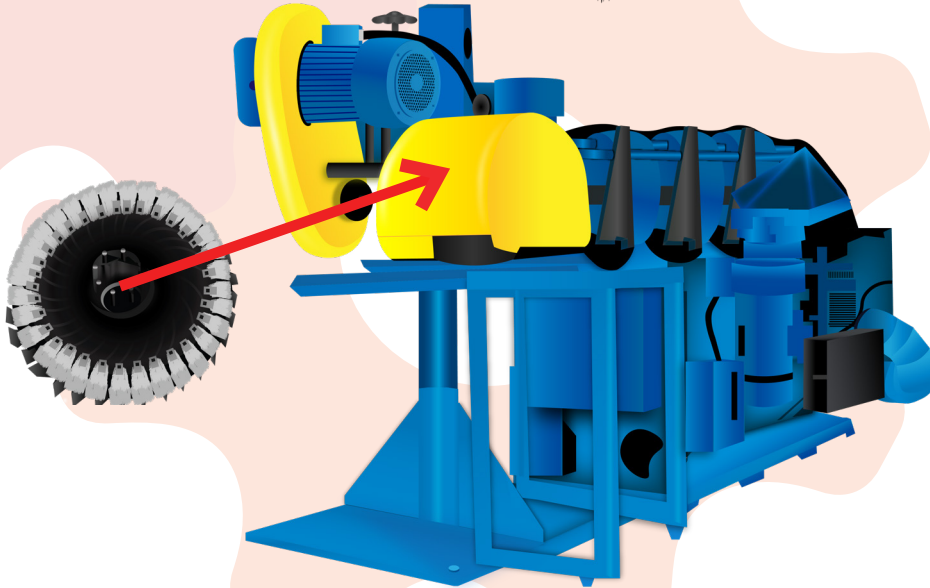

32 brush Wolfhead is mounted on a UA polishing lathe sanding moldings as they exit a molder.

Variable and Single Speed Polishing Lathes

Shown with optional belt attachments and tool rest. 5 to 20 H.P.

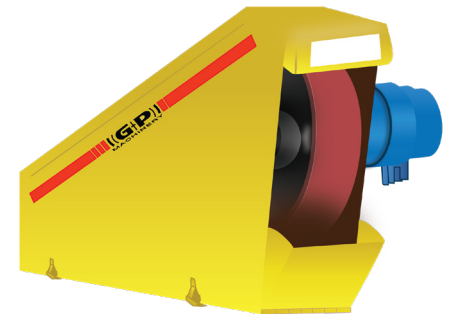
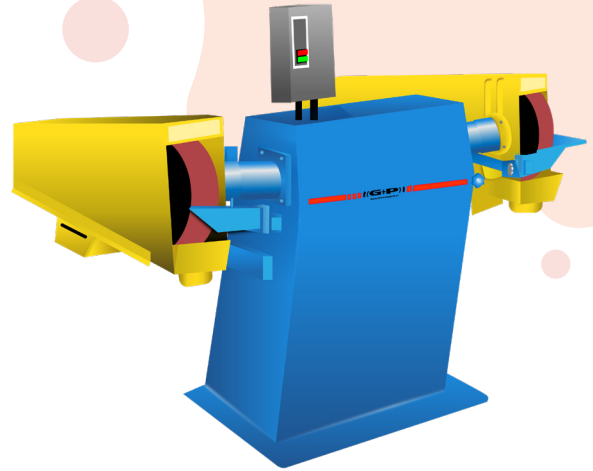

Belt Adaptor

Converts spindle stands to abrasive belt grinders.

Spindle Stands



EPN

2 H.P. – 1200 or 1800 RPM.
Shown with pneumatic drum and Wolfhead.

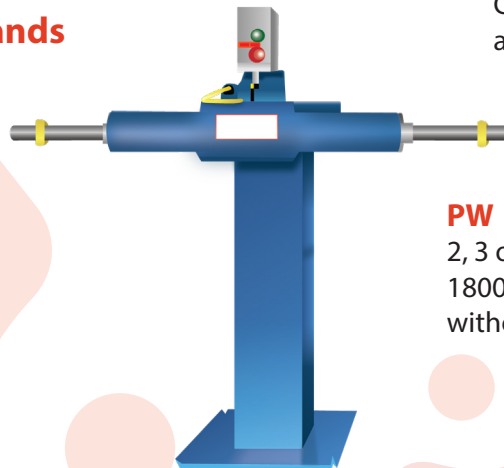

PW

2, 3 or 5 H.P. 1200 or 1800 RPM. Shown without guards.



GRINDING & POLISHING MACHINERY CORPORATION

2801 TOBEY DRIVE / INDIANAPOLIS, IN 46219
PHONE (317) 898-0750 • FAX (317) 899-1627

G&P MACHINERY BROCHURE

BROCHURE

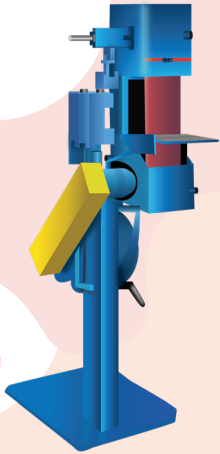

Platen Grinders Vertical or Horizontal

Wet or dry, available in 2 to 15 H.P.

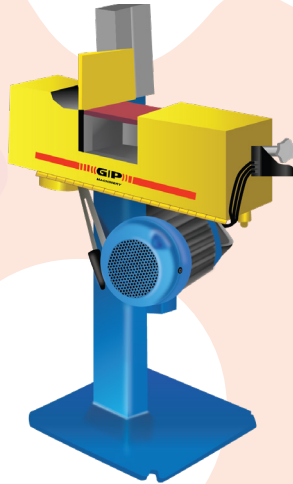

Pedestal Grinders

For off-hand grinding 2 to 7.5 H.P.



Lathe Mounted Polishers

Converts lathe into O.D. polisher. 2 to 7.5 H.P.

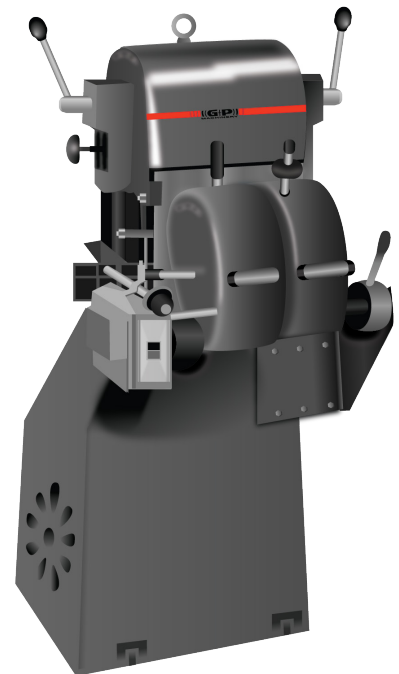

Cylindrical Polishers

Polishes straight or tapered shafts and cylinders from .5" to 3.5" diameters.



GRINDING & POLISHING MACHINERY CORPORATION

2801 TOBEY DRIVE / INDIANAPOLIS, IN 46219

PHONE (317) 898-0750 • FAX (317) 899-1627

G&P MACHINERY BROCHURE

BROCHURE STANDARD MACHINES

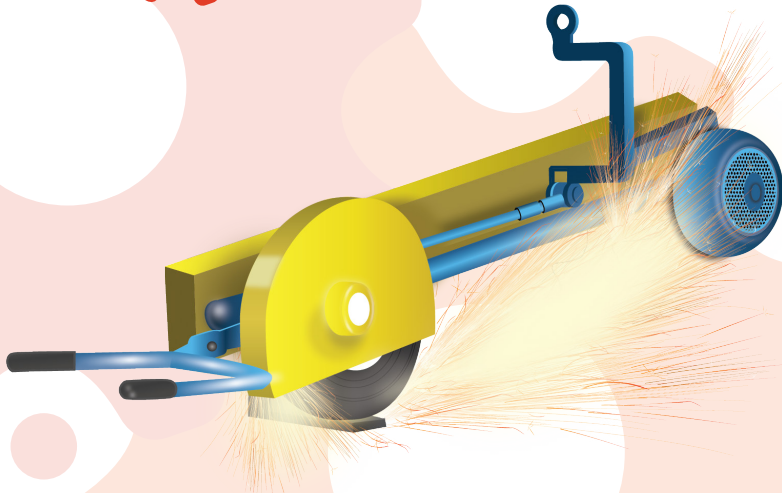

Swing Frame Grinders

Abrasive belt and hard wheel 2 to 25 H.P.

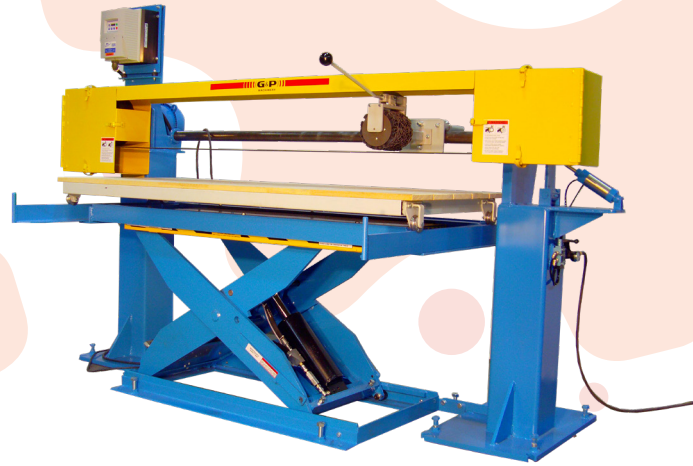

Stroke Sanders

Table sizes are 4, 6 and 8 feet long.
Options and accessories available.

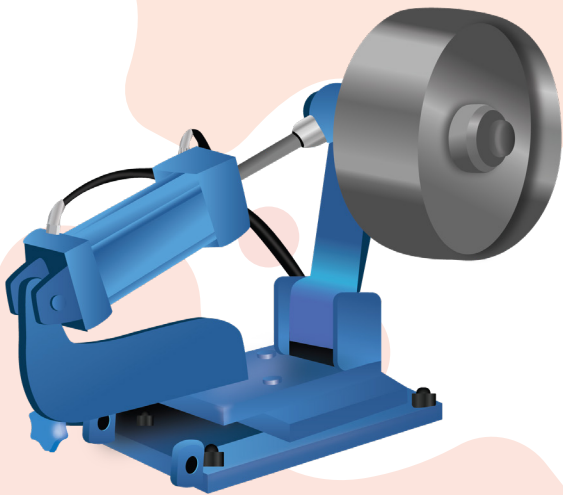

Backstand Idlers

Spring and air tension.

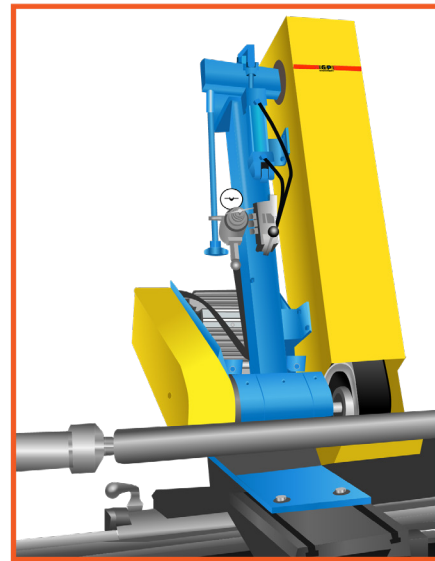

Lathe Mounted Roll Grinders

A variety of contact wheels are available making this grinder ideal for both roughing and finishing. Precision bearings and tapered spindle assure holding close tolerances and uniform finish.



GRINDING & POLISHING MACHINERY CORPORATION

2801 TOBEY DRIVE / INDIANAPOLIS, IN 46219

PHONE (317) 898-0750 • FAX (317) 899-1627

G&P MACHINERY BROCHURE

BROCHURE

CUSTOM BUILT MACHINES

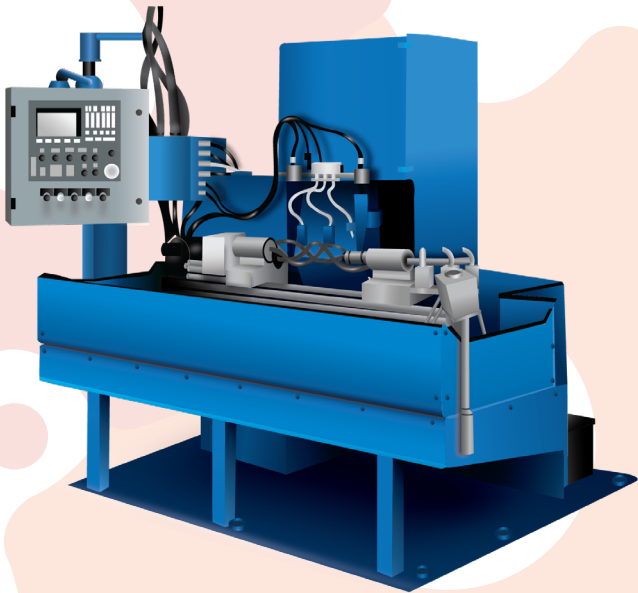

Power Grind

High pressure grinders. Reciprocating & rise and fall tables. 25 to 75 H.P. Single or dual motor. Single or multiple pass grinding.

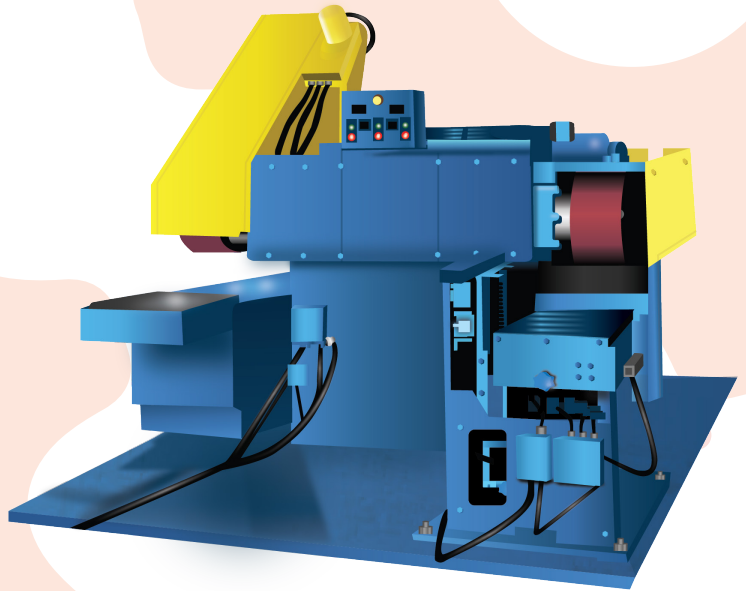

Cylinder Grinder

Abrasive belt grinding of ice cream beater blades to $\pm .002$ " tolerance.

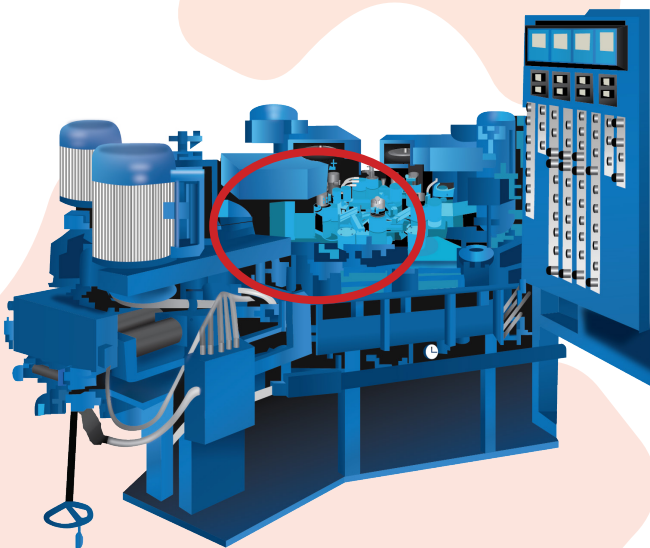

Brushing Turbine Blades with Nylon Brushes.

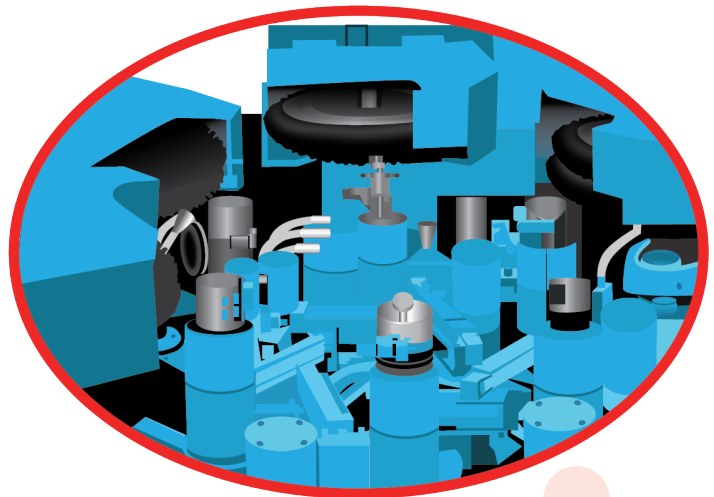

Rotary Indexing Machines



GRINDING & POLISHING MACHINERY CORPORATION

2801 TOBEY DRIVE / INDIANAPOLIS, IN 46219

PHONE (317) 898-0750 • FAX (317) 899-1627

G&P MACHINERY BROCHURE

BROCHURE MODIFIED STANDARDS

Right Angle I.D. Grinder

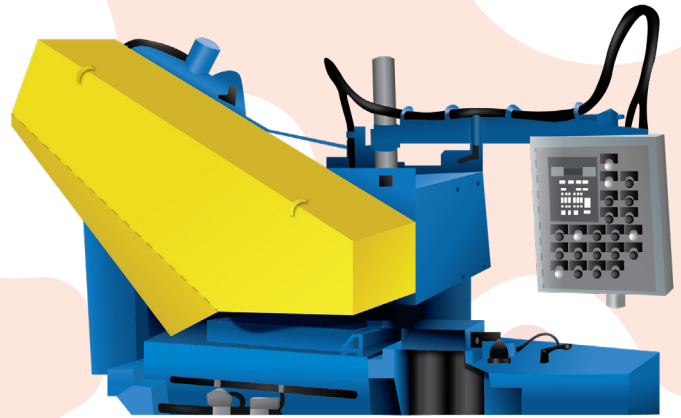
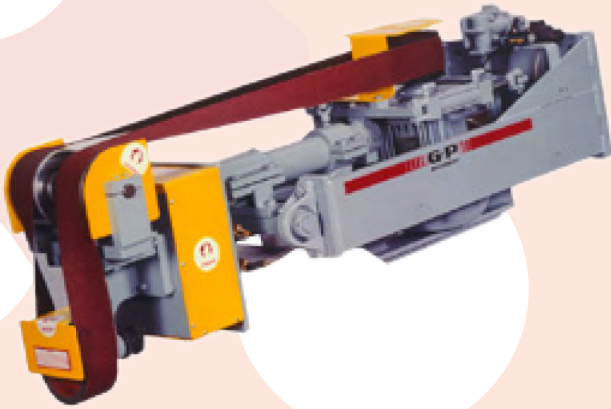

Reciprocating Grinder
Semi-Automatic and Programmable

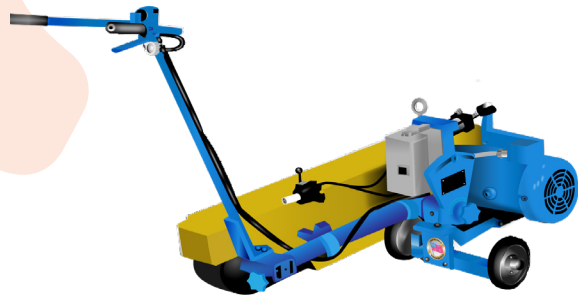

Platen Grinder
Manual & Self-Propelled

Grind Assist Tables
Pneumatic and Hydraulic

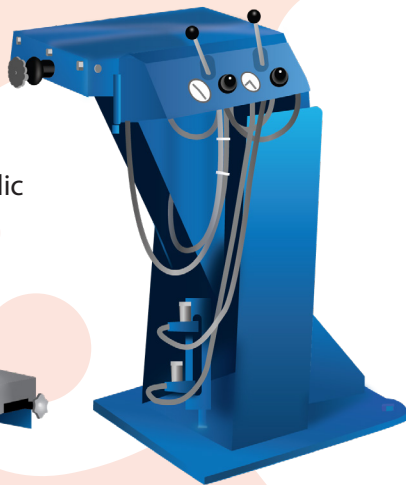
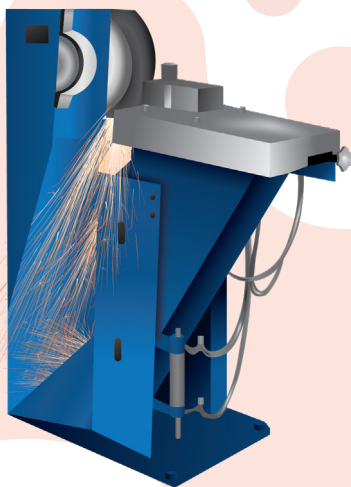

GRINDING & POLISHING MACHINERY CORPORATION
2801 TOBEY DRIVE / INDIANAPOLIS, IN 46219
PHONE (317) 898-0750 • FAX (317) 899-1627